

Algebra/Geometry Tutor Guide

Glossary of Terms

absolute value (of a number): the distance of the number from zero.

- The **absolute value** of a number is always positive.
 - The following are examples of absolute values.

$$|-5| = 5$$

$$|3| = 3$$

acute angle: an angle whose measure is between 0° and 90° .



acute triangle: a triangle with three acute angles.



addition operation: term + term = sum.

additive inverse (or opposite of a number, x): the unique number $-x$, which when added to x yields zero. $x + (-x) = 0$, just as $3 + (-3) = 0$

adjacent angles: two angles with the same vertex and a common side between them; angles 1 and 2 are adjacent angles.

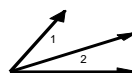

algebraic expression: a mathematical combination of constants and variables connected by arithmetic operations such as addition, subtraction, multiplication, and division.

- **Algebraic expressions** separate terms with operation symbols, but not equal signs.
 - The following are examples of algebraic expressions.

$$3x$$

$$5x + 7$$

$$x^2 - 11x - 12$$

algebraic fractions: fractions whose numerator and/or denominator are algebraic expressions.

- The following are examples of **algebraic fractions**.

$$\frac{3x}{5x + 7}$$

$$\frac{x^2 - 11x - 12}{x + 1}$$

algorithm: a rule (or step by step process) used to help solve a specific type of problem.

alternate exterior angles: when a line intersects two parallel lines, eight angles are formed; two angles that are outside (exterior) the parallel lines and on opposite sides (alternate) of the intersecting line are called alternate exterior angles.

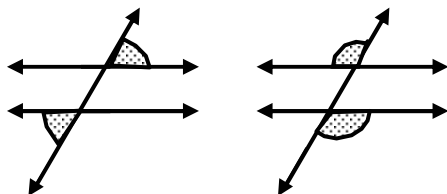

alternate interior angles: when a line intersects two parallel lines, eight angles are formed; two angles that are between (interior) the parallel lines and on opposite sides (alternate) of the intersecting line are called alternate interior angles.

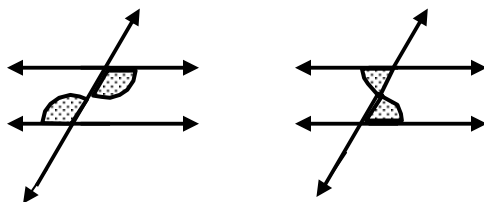

altitude: the perpendicular from a vertex to the opposite side (extended if necessary) of a geometric figure.

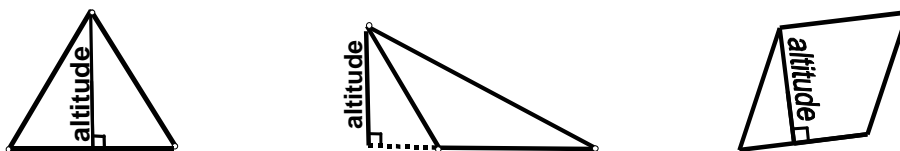

angle: the union of two rays with a common endpoint; angles are measured in a counter-clockwise direction; the angle's rays are labeled as initial and terminal sides with the terminal side counter-clockwise from the initial side.

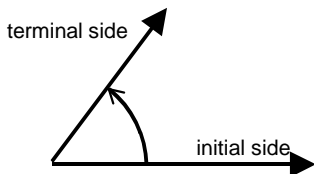

apothem: the apothem of a regular polygon is the radius of the inscribed circle.

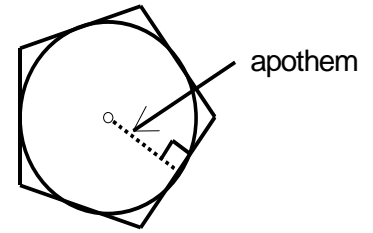

arc: any part of a circle that can be drawn without lifting the pencil.

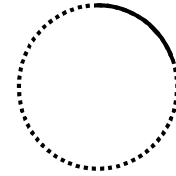

area: the measurement in square units of a closed figure.

• The following are examples of **area** problems.

Associative Property of Addition: terms to be combined may be grouped in any manner; this property of real numbers may be written using variables in the following way:
 $(a + b) + c = a + (b + c)$

Associative Property of Multiplication: terms to be multiplied may be grouped in any manner; this property of real numbers may be written in the following way:
 $a \cdot (b \cdot c) = (a \cdot b) \cdot c$.

auxiliary lines: lines which are added to a figure to help in visualizing a problem or to aid in the completion of a proof.

average: typical; although *mean*, *median*, and *mode* are all typical representations of a set of data, the mean is commonly referred to as the average.

- To find the **average** (mean) of a set of data, find the sum of the numbers in the set. Then, divide the sum by the number of members of the data set.
 - The following is the average of the set given. {1, 1, 2, 2, 4, 5, 5, 5, 6, 6}

$$\frac{1 + 1 + 2 + 2 + 4 + 5 + 5 + 5 + 6 + 6}{10} = \frac{37}{10} = 3.7$$

axiom: a statement that is accepted as true without proof.

base: the numbers being used as a factor in an exponential expression; in the exponential expression 2^5 , 2 is the base.

base angles of an isosceles triangle: the angles opposite the equal sides of an isosceles triangle are the base angles, which are also equal.

base of an isosceles triangle: the congruent sides of an isosceles triangle are called the legs, while the third side of the isosceles triangle is called the base.

- The following is an example of an **isosceles triangle**.

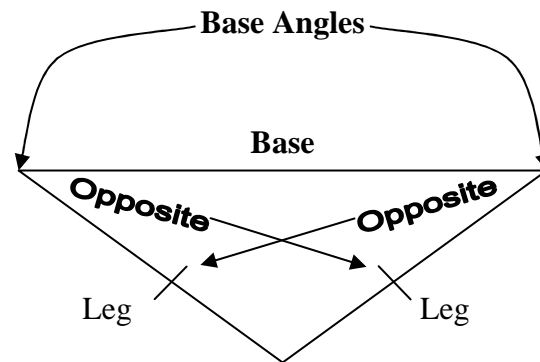

biconditional statement: a sentence joining a statement and its converse; the sentence includes the words *if and only if* which is abbreviated *iff*.

Example: Water freezes if and only if its temperature is 0° Celsius or below.

This is true since both of the following are true:

- (\rightarrow) If water freezes, then its temperature is 0° Celsius or below.
- (\leftarrow) If its temperature is 0° Celsius or below, then water freezes.

binary operation: an operation such as addition, subtraction, multiplication, or division that changes two values into a single value.

binomial: an algebraic expression consisting of two terms separated by an addition or subtraction sign.

- The following are examples of **binomials**.

$$x + 2 \quad x^2 - 7 \quad 5xy - x^3$$

bisector: a line that divides a figure into two equal parts.

- The following dotted lines are examples of bisectors.

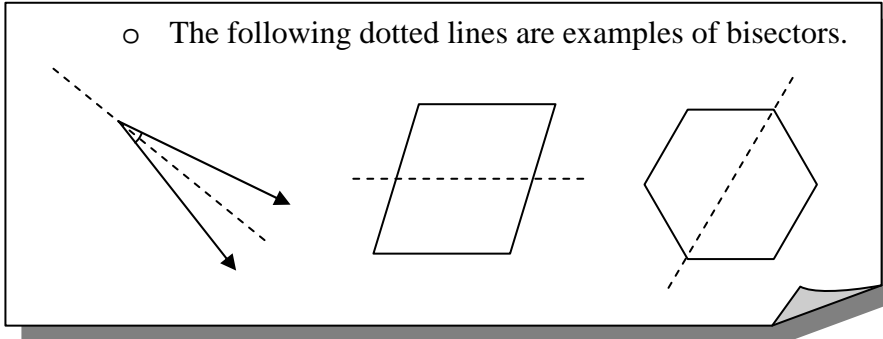

centi-: a prefix for a unit of measurement that denotes one one-hundredth ($\frac{1}{100}$) of the unit.

- Centi-** is a prefix used in the metric system. It can be used as centimeter, centiliter, or centigram.

central angle: an angle whose vertex is the center of a circle and whose sides are radii of the circle.

- $\angle AOC$ is a **central angle**. $\angle ABC$ is not.

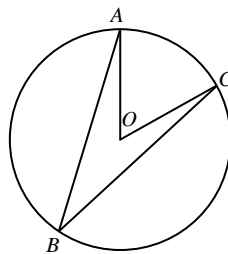

centroid: the point in which the medians of a triangle intersect.

- The medians of any triangle intersect at a common point called the **centroid**.

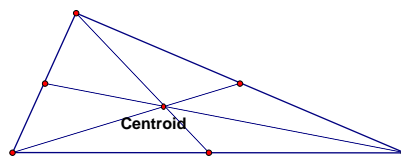

Chain Rule: a rule of logic that relates two conditional statements in the following manner.

Premise: If A then B

Premise: If B then C

Conclusion: If A then C

chord: a line segment with endpoints on a circle.

- Any segment that has its endpoints on a circle is a **chord**. Therefore, the diameter is a **chord**.
 - The following are all examples of **chords**.

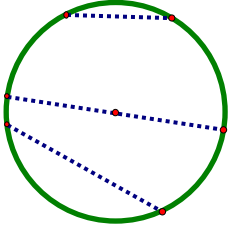

circle: the set of all points in a plane at a given distance (the radius) from a given point (the center).

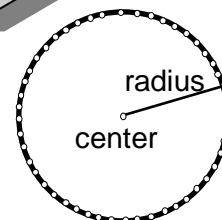

circumcenter: the point of intersection of the perpendicular bisectors of the sides of the triangle.

- The perpendicular bisectors of any triangle intersect at a common point called the **circumcenter**. The **circumcenter** is the center of a circle that has all three vertices of a triangle on it.

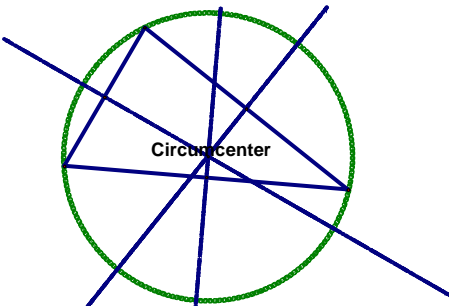

circumference: the distance around the edge of a circle.

circumscribe: a circle is said to be circumscribed about a polygon when all the vertices of the polygon lie on the circle.

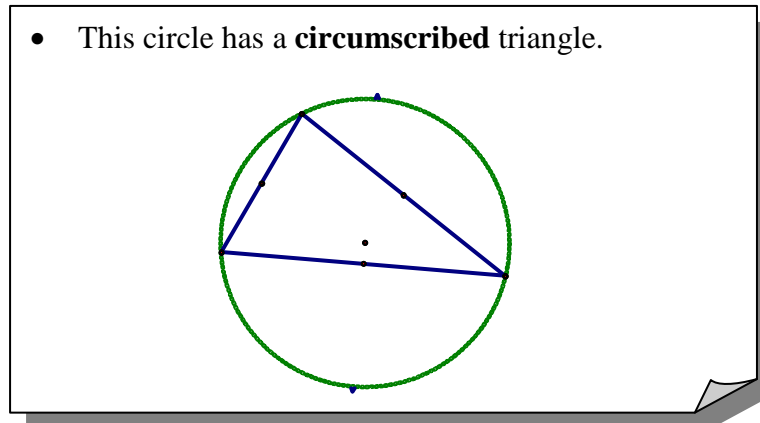

closed curve: a curve that can be drawn by starting and stopping at the same point without lifting your pencil.

- A circle is an example of a **closed curve**.

coefficient: the numerical part of a term.

- In the term $4x$, the 4 is the **coefficient**.

collinear: points on the same line.

- The points A , B , and C are **collinear**.

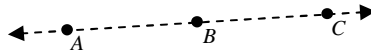

complementary angles: two angles whose sum is 90° .

- $\angle JMK$ and $\angle KML$ are **complementary**.

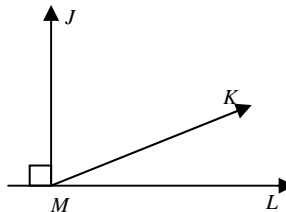

common factor: identical part of each term in an algebraic expression; in the expression $ab + ac$, the variable a is the common factor.

common tangent: a straight line that is tangent to each of two circles.

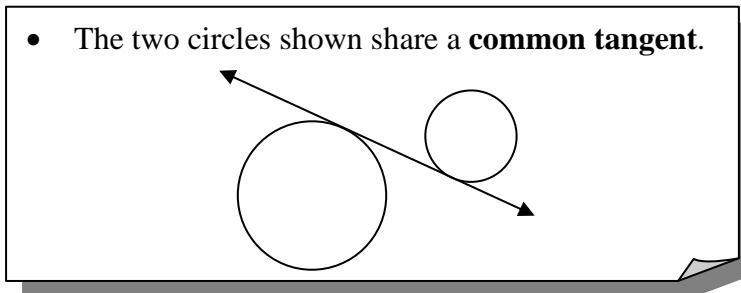

Commutative Property of Addition: terms to be combined may be arranged in any order; this property of real numbers may be written using variables in the following way:
 $a + b = b + a$

Commutative Property of Multiplication: terms to be multiplied may be arranged in any order; this property of real numbers may be written using variables in the following way: $a \cdot b = b \cdot a$

Comparison Axiom: if the first of three quantities is greater than the second **and** the second is greater than the third, **then** the first is greater than the third; if $a > b$ and $b > c$, then $a > c$.

complex fraction: a fraction whose numerator or denominator or both contain fractions.

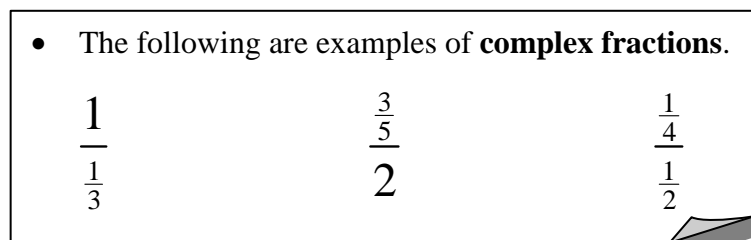

composite number: a natural number greater than one that has at least one positive factor other than 1 and itself.

compound statement: a statement connected by the words “**and**” or “**or**”.

concave polygon: if it is possible to draw a segment between two points of a polygonal region so that part of the segment lies outside the region, then the polygon is concave.



conclusion: the “**then**” part of a conditional statement.

concurrent: lines are said to be concurrent if there is exactly one point common to all of the lines.

- The three medians of a triangle are **concurrent**. The point where they intersect is called the *centroid*.

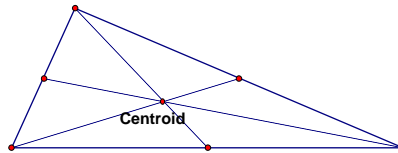

- The three altitudes of a triangle are **concurrent** and intersect at the *orthocenter*.

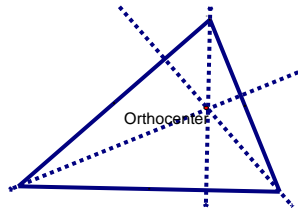

- The three perpendicular bisectors are **concurrent** and intersect at the *circumcenter*.

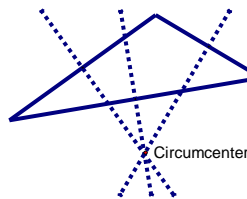

- ❖ Notice the *circumcenter* does not always have to be within the triangle.

conditional equation: an equation with a finite number of roots.

conditional statement (or implication): a statement of the form “if p , then q ”; a conditional statement is false only if p is true and q is false.

cone: a 3-dimensional surface composed of a circle and its interior, a point not on the plane of the circle, and all the segments from the point to the circle.

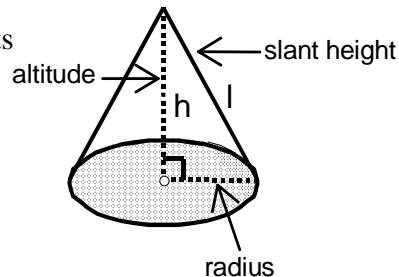

congruent figures: figures with the same shape and size.

conjecture: an educated guess.

conjunction: a compound statement connected by the word “**and**”; the compound statement (p and q) is true only if p is true and q is also true.

consecutive even integers: even integers that follow one another such as 2, 4, 6, etc.

consecutive integers: integers that follow each other on the number line such as 7, 8, 9, etc.

consecutive odd integers: odd integers that follow one another such as 5, 7, 9, etc.

constant: any symbol that has a fixed value such as 2 or π .

construction line: a line of indefinite length used as the foundation or starting position for a construction.

contingency: a logic statement that is sometimes true and sometimes false.

- A **contingency** is any logic value that can be considered true or false. The most basic **contingency** is p . This is because p can be either true or false.

p
T
F

For example, the statement “it is raining” is a contingency.

contraction: a process that reduces a figure, creating a smaller but similar figure.

- $\triangle A'B'C'$ is the **contraction** of $\triangle ABC$ about the origin.

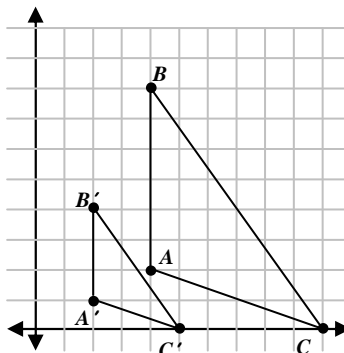

contradiction: a logic statement that is always false.

- A **contradiction** is any logic statement that is always false. The following is an example of a **contradiction**.

p	$\sim p$	$p \wedge \sim p$
T	F	F
F	T	F

contrapositive: a conditional statement formed by interchanging and negating both the hypothesis and the conclusion of the original conditional statement.

Original statement	Contrapositive
$p \Rightarrow q$	$\sim q \Rightarrow \sim p$

converse: if one of the facts in a hypothesis (the *given*) of a theorem or conditional statement is interchanged with one of the facts in the conclusion (the *to prove*), the resulting statement is a converse of the original one; a statement may have more than one converse.

Original statement	Converse
$p \Rightarrow q$	$q \Rightarrow p$

convex polygon: if a segment connecting any two points of a polygonal region is entirely inside the polygon, then the polygon is convex.

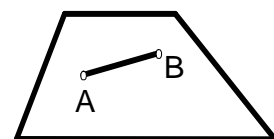

coplanar: coplanar points are points in the same plane.

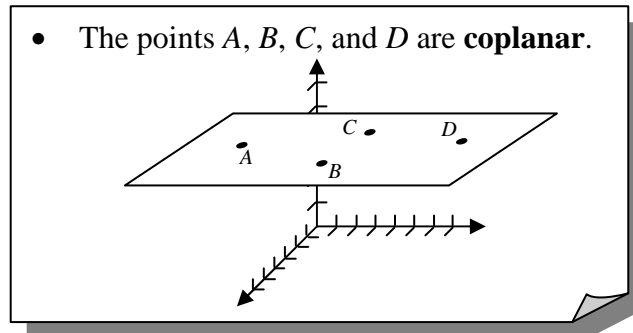

corollary: a theorem that is easily proven; it naturally follows or is a consequence of a proposition that has been proven.

corresponding angles: if a line intersects two parallel lines, eight angles are formed; two non-adjacent angles that are on the same side of the intersecting line but one between the parallel lines and one outside the parallel lines are called corresponding angles.

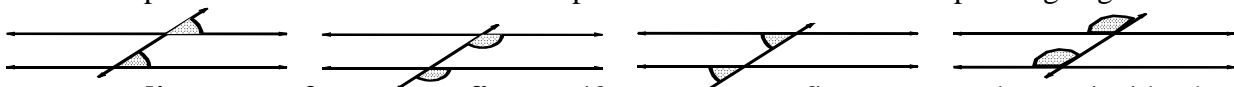

corresponding parts of congruent figures: if two congruent figures are made to coincide, the parts that match are called corresponding parts.

cosine (cos): in a right triangle, the cosine of one of the acute angles A is given by the

following ratio: $\cos A = \frac{\text{side adjacent } \angle A}{\text{hypotenuse}}$

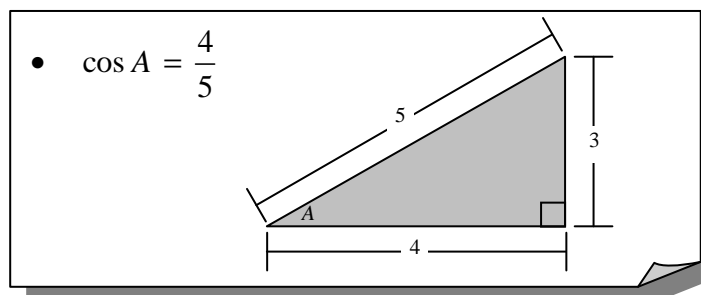

counter-example: an example that proves a statement false.

counting numbers (or natural numbers): the set of numbers $\{1, 2, 3, 4, 5, \dots\}$.

cross multiplication: the process of finding equal products in a proportion; if $\frac{a}{b} = \frac{c}{d}$ then

$$ad = bc.$$

cube: a regular 3-dimensional figure with six, equal, square sides.

- Dice are a real life example of **cubes**.



Dice

cube root: one of the three equal factors of a number.

- Since $3^3 = 3 \times 3 \times 3 = 27$, we know that $\sqrt[3]{27} = 3$

cylinder: a 3-dimensional surface composed of two congruent circles in parallel planes, the interior of the circles, and all the line segments that are parallel to the axis connecting the centers of the circles and have endpoints on the two circles.

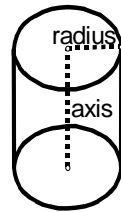

decagon: a ten-sided polygon.

deduction: a process of reasoning that involves drawing a conclusion based on given facts or hypotheses; also known as a **valid argument** or a **proof**.

degree of a constant: zero

- The **degree** of a term corresponds to the exponent attached to the variables. Since a **constant** is a number with no variable, its **degree** is zero. Think of it this way: any value raised to the zero power is 1. So, $3x^0 = 3(1) = 3$ is a **constant**. The exponent attached to the variable is zero, so the degree is zero.

degree of a monomial: the sum of the exponents of the variable factors.

- Here are some examples of **monomials** and their **degrees**.

Monomial	Degree
$3x$	1
$5x^2$	2
$7x^2y^3z$	6

- Remember, if a variable has no exponent written, the exponent is 1.

degree of a polynomial: the highest degree of any monomial in a polynomial.

- Here are some examples of **polynomials** and their **degrees**.

Polynomial	Degree
$3x + 1$	1
$5x^2 + 6x + 1$	2
$7x^2y^3z - 11x^2y + 2y^2$	6

denominator: the bottom part of a fraction.

dense: a set of numbers is dense if no matter how close together two numbers in the set are, another in the set can be found in between them.

descending order: arrangement of the terms of a polynomial so the first term has the highest degree and each succeeding term is of lesser degree than the term before it.

diagonal: a line segment with endpoints on two non-consecutive vertices of a polygon.

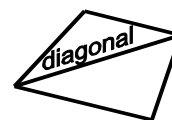

diagonal of a prism: any segment of a prism with endpoints on two vertices that do not lie in the same face of the prism.

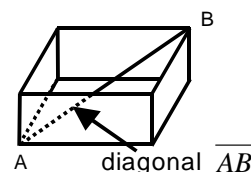

diameter: a line segment that passes through the center of a circle and whose endpoints are points on the circle.

- The **diameter** is a *chord* that goes through the center of the circle. The **diameter** is twice the *radius*.

difference: the answer to a subtraction problem.

dilation: a process that expands a figure creating a similar but larger figure.

- $\triangle A'B'C'$ is the **dilation** of $\triangle ABC$ about the origin.

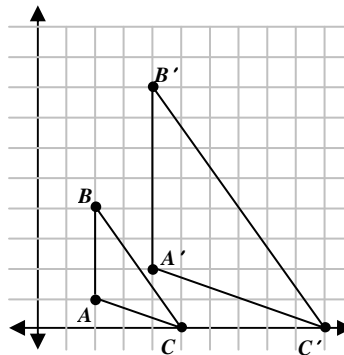

direct reasoning: a rule of logic that relates two premises in the following manner:

Premise: If A then B

Premise: A

Conclusion: B

disjunction: a sentence joining two statements with the word “**or**.”

Distributive Property of Multiplication over Addition: a property of real numbers used to write equivalent expressions in the following way: $a(b + c) = a \cdot b + a \cdot c$

Distributive Property of Multiplication over Subtraction: a property of real numbers used to write equivalent expressions in the following way: $a(b - c) = a \cdot b - a \cdot c$

dividend: the number being divided in a quotient; in $b \overline{)a}$ or $\frac{a}{b} = c$, a is the dividend.

division operation: $\frac{\text{Dividend}}{\text{Divisor}} = \text{Quotient}$ or $\text{Divisor} \overline{) \text{Dividend}}$ Quotient

dominoes: figures formed of two congruent squares placed so that the squares share a side.

elements (of a set): the objects that belong to a set.

ellipse: a plane curve whose path is that of a point, and the sum of whose distances from two fixed points (called the *foci*) is a constant.

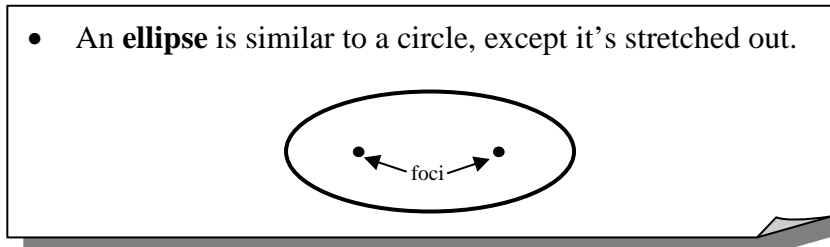

empty set: a set that has no elements in it.

Equal Quantities Axiom: quantities which are equal to the same quantity or to equal quantities, are equal to each other.

equation: a mathematical statement that two quantities are equal to one another.

equiangular polygon: a polygon with all angles equal.

equiangular triangle: a triangle with all angles equal.



equilateral polygon: a polygon with all sides equal.

equilateral triangle: a triangle with all sides equal.

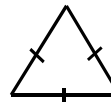

- An **equiangular triangle** is also an **equilateral triangle**. However, an **equiangular polygon** is not necessarily an **equilateral polygon**.

equivalent equations: equations with the same solution set.

exclusive or: indicates one or the other, but not both.

Existence Property: a property that guarantees a solution to a problem.

existential quantifier: \exists is the existential quantifier. It is read, "**there exists**" or "**for some**."

exponent: tells how many times a number called the base is used as a factor; in $2^3 = 8$, three (3) is the exponent.

exterior angle: is an angle formed by one side of a polygon and an adjacent side extended.

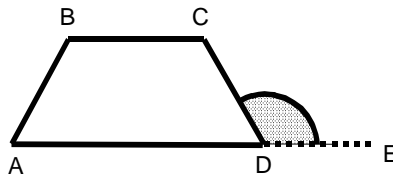

extraneous root: apparent solution to an equation that does not actually satisfy the equation.

extremes: the first and fourth terms in a proportion are called the extremes.

- In the following proportion, a and d are the **extremes**.

$$\frac{a}{b} = \frac{c}{d}$$

factor: one of the numbers multiplied together in a product; if $a \cdot b = c$, then a and b are factors of c .

factored form (of a polynomial): product of the prime factors of a polynomial; the expression $a(b + c)$ is written in factored form.

factoring: writing an expression in **factored form**.

fractals: irregular and fragmented shapes such that a small part of the shape resembles the whole shape.

- A **fractal** is made by taking a shape, *contracting* it, and organizing it so that it follows a general pattern. Then, this pattern is repeated as many times as desired.

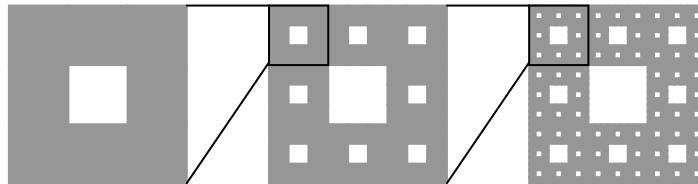

Fundamental Theorem of Arithmetic: every composite number may be written uniquely (disregarding order) as a product of primes.

geometry: the branch of mathematics that investigates relations, properties, and measurements of solids, surfaces, lines, and angles.

gram (g): a basic unit of mass in the metric system; 1 gram \approx .035 ounces.

great circle: a great circle is a circle formed on the surface of a sphere by passing a plane through the center of the sphere. A and B are points on one great circle and C and D are points on another great circle.

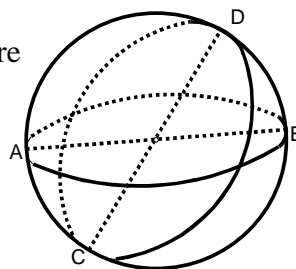

Greatest Common Factor (GCF): the largest value that divides two or more terms.

heptagon: a seven-sided polygon.

hexagon: a six-sided polygon.

hexominoes: figures formed using six congruent squares, placed so that each square shares a side with at least one other square.

hyperbola: a plane curve whose path is that of a point, such that the difference of the distances from the point to two other points (called foci) in the plane is a positive constant.

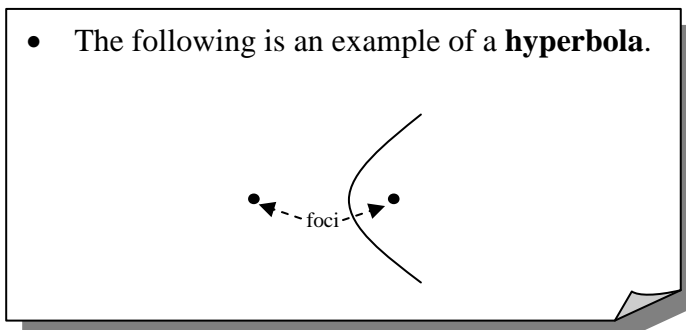

hypotenuse: the side opposite the right angle in a right triangle.

hypothesis: the “if” part of a conditional statement.

icosahedron: a polyhedron with 20 faces.

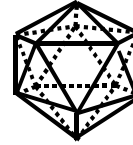

identity: an equation that is true for all values of the variable; every real number is a root of an identity.

Identity Element for Addition: zero is the additive identity element because 0 may be added to any number and the number keeps its identity; $a + 0 = 0 + a = a$ for any real number a .

Identity Element for Multiplication: one (1) is the multiplicative identity element because any number may be multiplied by 1 and the number keeps its identity; $1 \cdot a = a \cdot 1 = a$ for any real number a .

impossible equation: an equation that is not true for any value of the variable; an impossible equation has no roots.

incenter: the point of intersection of the bisectors of the angles of a triangle is called the incenter of the triangle.

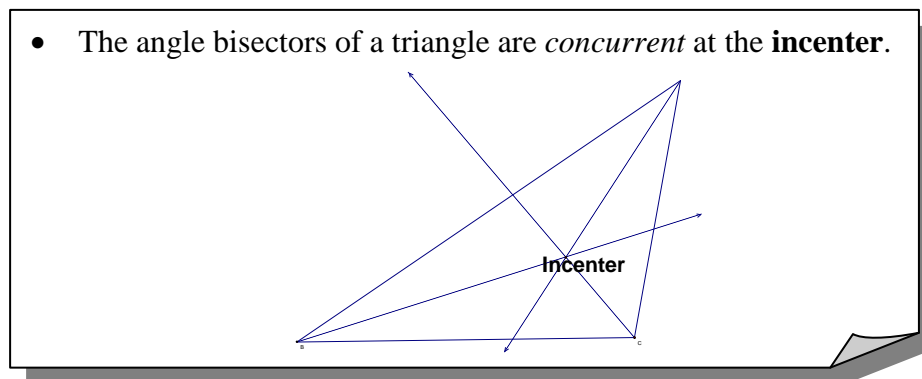

inclusive or: implies one *or* the other *or* both.

index: the number outside the radical sign that indicates which root is being found; in $\sqrt[3]{x}$, three is the index.

indirect reasoning: a rule of logic that relates two premises in the following manner:

Premise: If A then B

Premise: Not B

Conclusion: Not A

inductive reasoning: the process of reasoning by drawing conclusions on the basis of examples and experience.

inner product: part of the product when binomials are multiplied;

$$(a + b)(c + d) = ac + ad + \underbrace{bc}_{\uparrow} + bd; \text{ the term } bc \text{ is the inner product.}$$

integers: the natural numbers, zero, and the additive inverses of the natural numbers;

$$\{\dots -3, -2, -1, 0, 1, 2, 3\dots\}$$

irrational number: a real number that cannot be written as the quotient of two integers; an irrational number, written as a decimal, does not terminate and does not repeat.

For example, the number pi $\pi = 3.14159268\dots$

inscribed angle: an angle whose vertex lies on a circle and whose sides are chords of the circle.

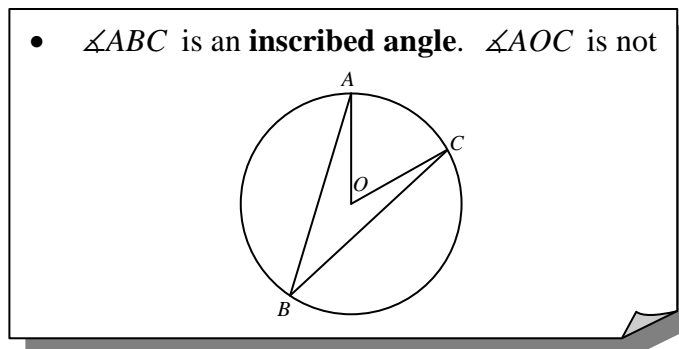

inscribed polygon: all the vertices of a polygon lie on a circle surrounding it.

interior angle: an angle that lies inside a polygon and is formed by two adjacent sides of the polygon.



intersect: to cross; two lines in the same plane intersect if and only if they have exactly one point in common.

intuition: knowledge gained instinctively without the help of reasoning.

inverse: a conditional statement resulting from negating both the hypothesis and the conclusion of the original condition statement.

Original statement	Inverse
$p \Rightarrow q$	$\sim p \Rightarrow \sim q$

isometric dot paper: paper that has diagonal rows of dots that form a 30° angle with the horizon.

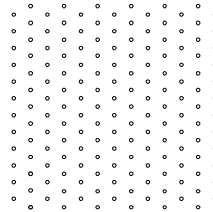

isosceles trapezoid: a trapezoid whose non-parallel sides (or legs) are congruent.

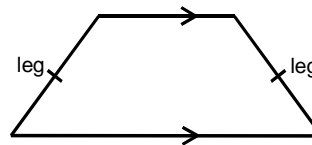

isosceles triangle: a triangle with two equal sides.



justification: a process by which one states the reasons for one's beliefs with a convincing argument.

kilo: a prefix for measurement that denotes one thousand (1000) units.

kite: a quadrilateral with two pairs of adjacent sides congruent and no opposite sides congruent.

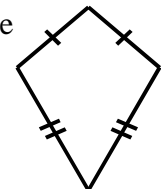

Law of Contraposition: see indirect reasoning.

Law of Detachment: see direct reasoning.

Least Common Multiple (LCM): the least common multiple of two or more positive values is the smallest positive value that is a multiple of each.

legs of an isosceles triangle: the congruent sides of an isosceles triangle are called its legs.

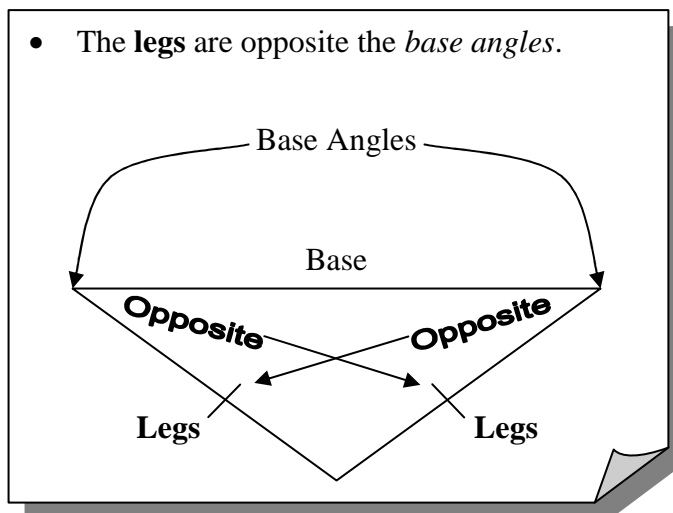

line: one of the undefined terms; consists of a set of points extending without end in opposite directions.

line segment: a subset of a line that contains two points of the line and all points between those two points.

locus: the path of a point that satisfies certain conditions.

logically equivalent: two statements that have exactly the same truth tables.

- The statement $p \rightarrow q$ is **logically equivalent** to $\sim p \vee q$

p	q	$p \rightarrow q$	$\sim p \vee q$
T	T	T	T
F	T	T	T
T	F	F	F
F	F	T	T

lowest common denominator (lcd)(of two or more fractions): the least common multiple of the denominators of the fractions.

like radicals: radical expressions with the same radicand and the same index.

like terms: terms which have identical variable factors.

liter (L): a basic unit of volume in the metric system; 1 liter \approx 1.06 liquid quarts.

literal equation: an equation that contains at least two different variables.

major arc: an arc of a circle that is greater than a semicircle.

- You must use three points on the circle to describe the **major arc**. \widehat{ABC} is a **major arc**.

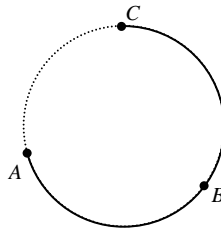

mean (or arithmetic mean): the sum of a set of data divided by the number of items of data in the set.

mean proportional: in the proportion $\frac{a}{b} = \frac{b}{c}$, b is called the mean proportional.

means: the second and third terms in a proportion.

- In the following proportion, b and c are the **means**.

$$\frac{a}{b} = \frac{c}{d}$$

median: the middle number in a given sequence of numbers.

- To find the **median** of a set of numbers, place them in order and locate the middle number. If there are two numbers in the middle, the average of those two numbers is the **median**.

median of a triangle: a line drawn from any vertex to the midpoint of the opposite side.

median of a trapezoid: a line connecting the mid-points of the non-parallel sides.

meter (m): a basic unit of length in the metric system; 1 meter \approx 39.37 inches.

milli: a prefix for a unit of measurement that denotes one one-thousandth ($\frac{1}{1000}$) of the unit.

minor arc: an arc of a circle that is less than a semicircle.

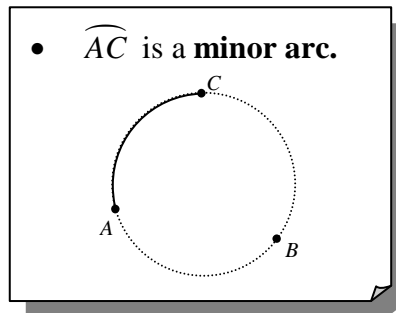

minuend: the number from which something is subtracted; in $5 - 3 = 2$, five (5) is the minuend.

Modus Ponens: see direct reasoning.

Modus Tollens: see indirect reasoning.

monomial (or term): a single number, a single variable, or a product of a number and one or more variables.

• The following are examples of **monomials**.

$$3 \quad 3x \quad 3x^2y^3$$

multiplicative inverse (or reciprocal of a real number x): the unique number, $\frac{1}{x}$, which,

when multiplied by x , yields 1. $x \cdot \frac{1}{x} = 1$ if $x \neq 0$.

multiplication operation: factor \times factor = product

multiplicative property of zero: for any real number a , $a \cdot 0 = 0 \cdot a = 0$.

natural numbers (or counting numbers): the set of numbers $\{1, 2, 3, 4, 5, \dots\}$.

negative integers: the opposite of the natural numbers.

negative of a statement: the same statement rewritten with the opposite truth-value.

net: a 2-dimensional figure that can be folded to make a 3-dimensional geometric figure.

• The following are examples of **nets**.

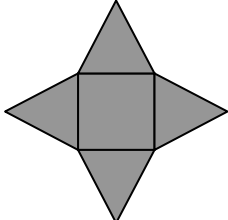

Square Pyramid

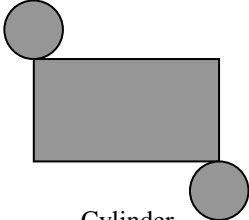

Cylinder



Rectangular Prism



net for a cube: a hexomino that can be folded into a cube is known as a net for a cube.

• Not all *hexominoes* can make a **net for a cube**.

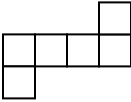
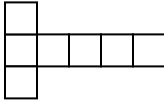
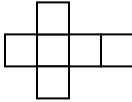
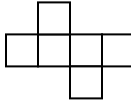
○ The following are *hexominoes* that can be folded into a cube.

○ The following are *hexominoes* that cannot be folded into a cube.

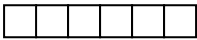

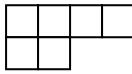
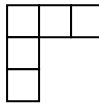



nonagon: a nine-sided polygon.

numerator: the top part of a fraction.

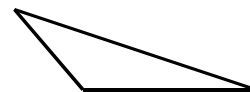
obtuse angle: an angle that measures between 90° and 180°

obtuse triangle: a triangle with one obtuse angle.



octagon: an eight-sided polygon.

orthocenter: the point in which the altitudes of a triangle intersect.

- The altitudes of a triangle are *concurrent* at a point called the **orthocenter**.

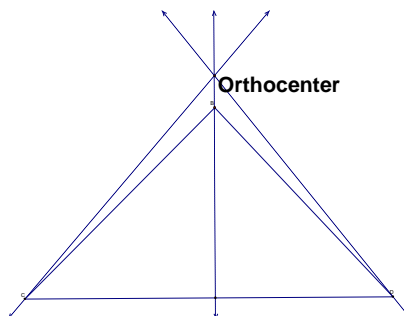

- ❖ Notice the **orthocenter** does not always have to be within the triangle. Both the **orthocenter** and the *circumcenter* are outside the triangle when the triangle is obtuse.

orthographic projections: views of an object “straight on” or perpendicular to a plane or face of the object; six orthographic views of 3-dimensional objects are usually shown: the top, the bottom, the front, the back, the left side and the right side.

octahedron: a polyhedron with eight faces.

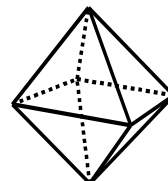

outer product: part of the product when binomials are being multiplied;

$$(a + b)(c + d) = ac + \underbrace{ad}_{\uparrow} + bc + bd; \text{ the term } ad \text{ is the outer product.}$$

parabola: a plane curve whose path is that of a point that is equidistant from a point called the focus and a line called the directrix.

- The following is an example of a **parabola**.

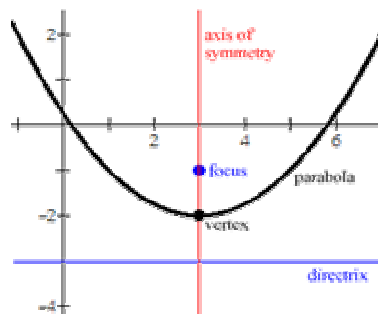

paradox: a statement that is neither true nor false.

parallel lines: lines in the same plane that do not intersect; the two lines are everywhere equidistant.

parallelogram: a quadrilateral whose opposite sides are parallel.



pentagon: a five-sided polygon.

pentominoes: figures formed using five congruent squares placed so that each square shares a side with at least one other square.

percent: divided by 100; the symbol for percent is %.

perfect square: a number whose square root is a natural number.

perimeter: the sum of the lengths of the sides of a figure or the distance around the figure.

perpendicular lines: two lines that form a right angle.

perspective: the technique of drawing objects and spatial relationships on a flat surface so that they appear three dimensional.

plane: one of the undefined terms; a set of points that form a flat surface extending without end in all directions.

- A **plane** must be defined by at least three points. The points *A*, *B*, and *C* form a **plane**.

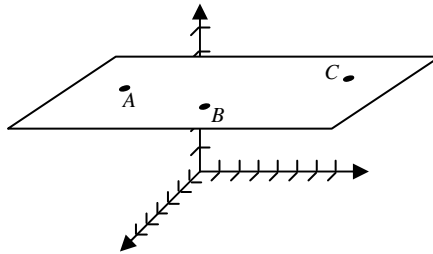

plane geometry: the branch of mathematics that deals with figures that lie in a plane or flat surface.

point: one of the undefined terms; a location with no width, length, or depth.

polygon: a closed figure bounded by line segments.

polyhedron (plural – polyhedra): a simple, closed, three-dimensional form whose surfaces are polygons.

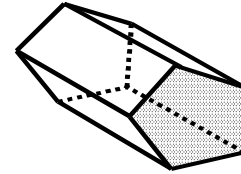
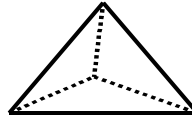
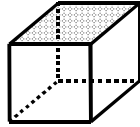

The flat polygonal surfaces of a polyhedron are called its **faces**.

The face of a polyhedron includes the polygon and its interior region.

A segment where two faces intersect is an **edge** of a polyhedron.

A point of intersection of three or more edges is a **vertex** of a polyhedron.

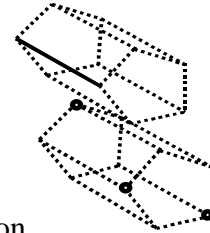

polynomial: an algebraic expression consisting of one or more terms separated by addition or subtraction signs.

- The following are examples of **polynomials**.

$$3 - x$$

$$3x + y$$

$$3x^2y^3 - 5xy + 2$$

positive integers: the collection of numbers known as **natural numbers**.

postulate: a statement that applies to geometry and is assumed to be true without proof.

premise: a statement used as a basis for drawing a conclusion.

prime numbers: the natural numbers greater than one (1) that have exactly two factors, one (1) and themselves.

principal square root: the non-negative square root of a number.

prism: a polyhedron with two congruent polygonal faces in parallel planes (bases) and the other faces bounded by parallelograms (lateral faces).

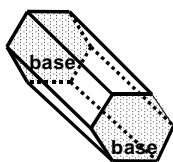

lateral faces

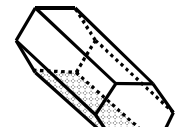
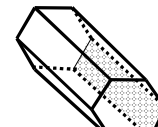
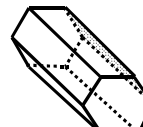
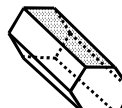
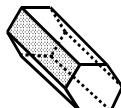
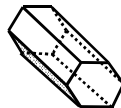

product: the result when two or more numbers are multiplied.

proof: a valid argument that follows logically from premises; the validation of a statement beyond any shadow of a doubt; also known as a **deduction**.

proof by contradiction (or indirect proof): uses the fact that to prove one of two contradictory statements true it is sufficient to prove that the other one is false; in other words, to prove a statement is true, assume that it is false and show that this leads to a contradiction.

proof by demonstration: showing the existence of a solution.

proof by exhaustion: showing that a property or assumption works in every case.

Property of Congruence: any angle or line segment is congruent to itself; called the reflexive property of congruence.

proportion: an equality of two ratios.

proposition: a statement of a geometric truth.

pyramid: a polyhedron determined by a polygonal region, a point not in the plane of the region and triangular regions determined by the point and each pair of consecutive vertices of the polygonal region; the polygonal region is called the base of the pyramid, the triangular regions are lateral faces, and the point is called the apex.

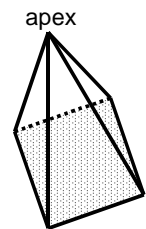

quadrilateral: a polygon with four sides.

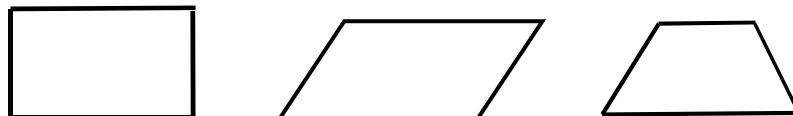

quantifiers: words such as **some**, **all** (or **every**), and **no** (or **none**) **sometimes**, **always**, and **never** which are used to change the meaning of a statement or make it more explicit.

quotient: the number resulting from the division of one number by another.

radical: the symbol that tells you a root is to be taken; denoted by $\sqrt{\quad}$.

radicand: the number inside the radical sign whose root is being found; in $\sqrt{7x}$, $7x$ is the radicand.

radius (radii): a line segment with endpoints on the center of the circle and a point on the circle.

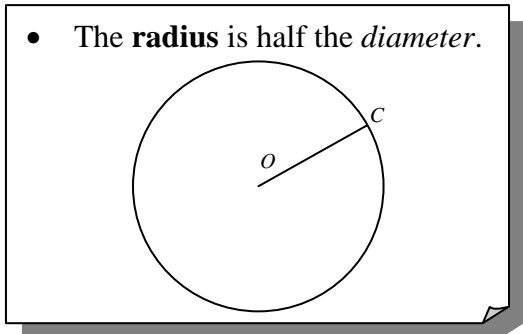

ratio: proportional relation between two quantities or objects in terms of a common unit.

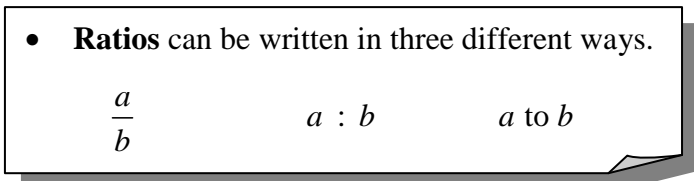

rational equations: equations that contain one or more rational expressions.

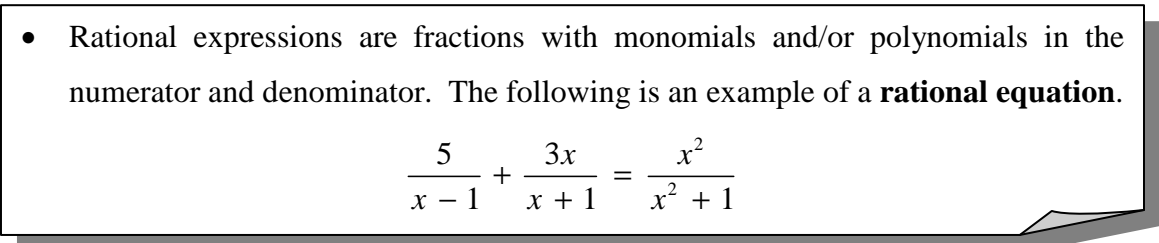

rational numbers: the collection of numbers that can be expressed as the quotient of two integers; when written as a decimal it will terminate or repeat.

ray: a subset of a line that consists of a point and all points on the line to one side of the point.

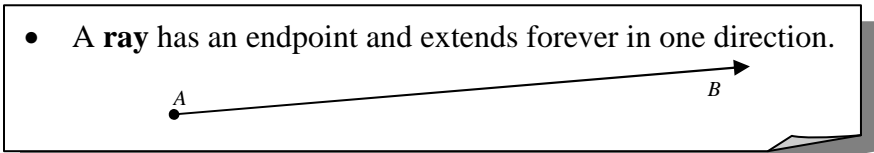

real numbers: the combined collection of the rational numbers and the irrational numbers.

reciprocal (or multiplicative inverse of a real number x): the unique number which, when multiplied by x , yields 1; $x \cdot \frac{1}{x} = 1$ if $x \neq 0$.

rectangle: a parallelogram with one right angle.



reflection (or flip): a transformation of an object that creates a mirror image.

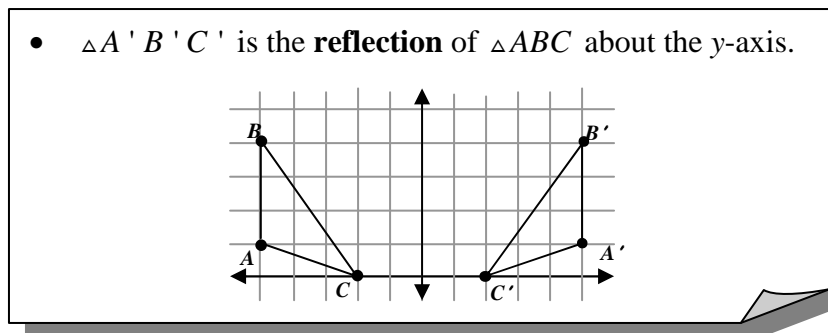

reflex angle: an angle greater than a straight angle and less than two straight angles.

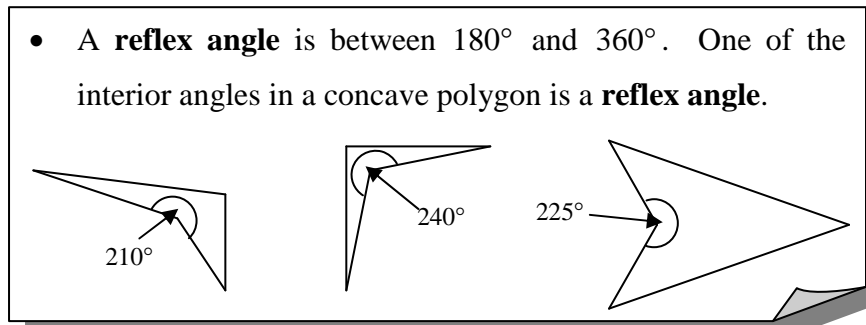

regular polygon: a polygon whose sides and angles are all equal.

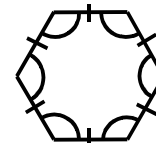

regular polyhedron: a convex polyhedron with all faces identical regular polygons; the number of edges that meet at a vertex is the same at every vertex.

relatively prime: a pair of numbers with no common factor other than 1.

repeating decimal: a decimal with an infinite number of digits to the right of the decimal point created by a repeating set pattern of digits.

rhombus (rhombi): a parallelogram having two adjacent sides equal.

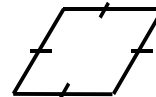

right angle: an angle whose sides are perpendicular; having a measure of 90 degrees.

right prism: a prism whose lateral faces are all bounded by rectangles.

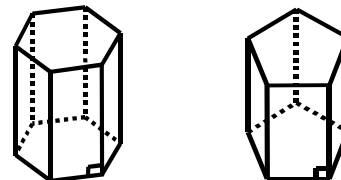

right triangle: a triangle with one right angle.

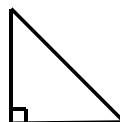

- In a **right triangle**, the *circumcenter* is the median of the hypotenuse, and the *orthocenter* is the vertex of the right angle.

right pyramid: a pyramid whose altitude intersects the base of the pyramid in the center of the base.

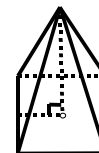

root: the solution to an equation.

rotation: a transformation of an object created by holding one point, called the center, fixed and moving the object a given angle in a given direction.

- $\triangle A'B'C$ is a 90-degree rotation of $\triangle ABC$ about the point C .

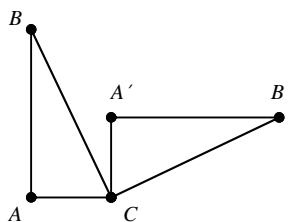

scalene triangle: a triangle with no two sides of equal measure.

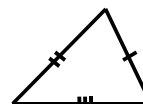

scientific notation: a shorthand way of writing very large or very small numbers; the product of a decimal number greater than or equal to 1 but less than 10 and a power of 10.

secant: a straight line intersecting a circle in exactly two points.

sector of a circle: the figure bounded by two radii and an included arc of the circle.

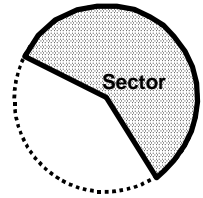

semicircle: an arc equal to half of a circle is called a semicircle.

set: a collection of objects.

similar figures: figures with the same shape but not necessarily the same size.

similar polygons: polygons whose corresponding angles are congruent and whose corresponding sides are proportional; the symbol \sim is used to indicate that figures are similar.

simple curve: a curve that does not cross itself.

sine (sin): in a right triangle, the sine of one of the acute angles, A , is given by the following

ratio: $\sin A = \frac{\text{side opposite } \angle A}{\text{hypotenuse}}$

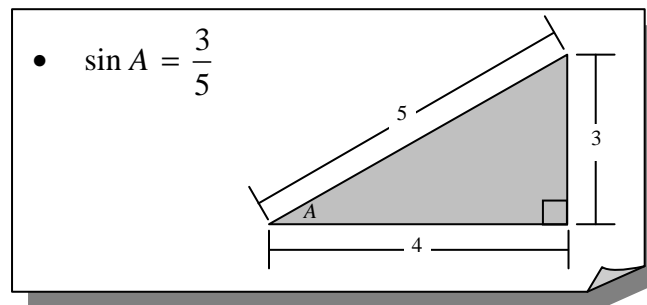

solid: A geometric figure having three dimensions.

solid geometry: the part of mathematics that deals with three-dimensional shapes and their properties.

solution: a value that makes the two sides of an equation equal.

solution set: the set of all roots of the equation.

sphere: a 3-dimensional surface consisting of all points at a given distance, called the radius, from a given point, called the center.

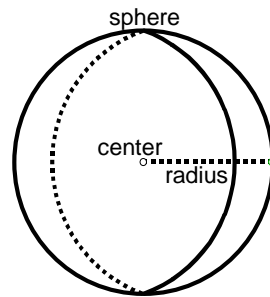

square: a rectangle having two adjacent sides equal.

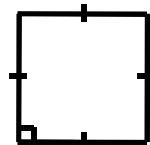

square root: one of the two equal factors of a number.

statement: a declarative sentence that is either true or false, but not both.

straight angle: an angle measuring 180° .

subset: B is a subset of A, written $B \subseteq A$, if and only if every element of B is an element of A.

Substitution Axiom: a quantity may be substituted for its equal in any expression.

subtraction operation: $\frac{\text{Minuend}}{\text{Difference}} - \text{Subtrahend}$ or $\text{Minuend} - \text{Subtrahend} = \text{Difference}$

subtrahend: the number being subtracted in a subtraction problem; in $5 - 2 = 3$, 2 is the subtrahend.

sum: the result when two numbers are added.

supplementary angles: two angles whose sum is 180° .

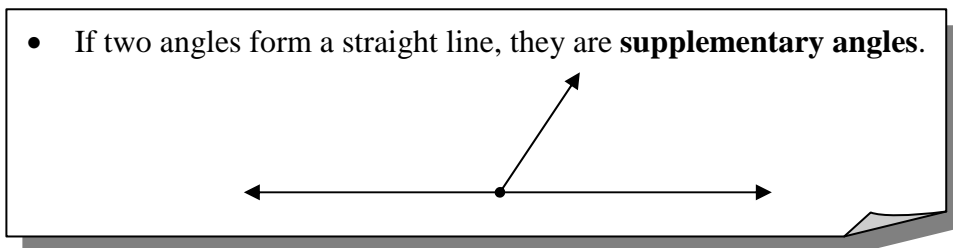

surface: one of the faces of an object.

tangent: a straight line touching a circle in one and only one point; the ratio of the side opposite the angle to the side adjacent the angle; $\tan A = \frac{\text{side opposite } \angle A}{\text{side adjacent } \angle A}$

- The **tangent** of a circle is always *perpendicular* to the radius that intersects the **tangent**.

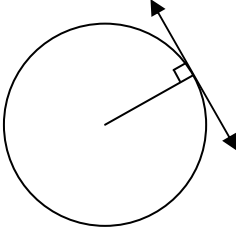

- $\tan A = \frac{3}{4}$

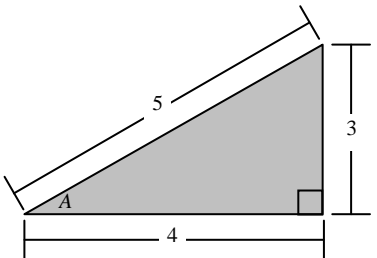

tangent circles: two circles that are both tangent to the same line at the same point.

- The following is an example of **tangent circles**.

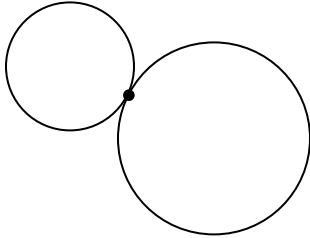

tautology: a logic statement that is always true.

- A **tautology** is any logic statement that is always true. The following is an example of a **tautology**.

p	$\sim p$	$p \vee \sim p$
T	F	T
F	T	T

term: a single number, a single variable, or a product of a number and one or more variables.

terminating decimal: a decimal with a finite (or countable) number of digits to the right of the decimal point.

tessellation: the filling of a plane with repetitions of figures in such a way that no figures overlap and there are no gaps.

• In two-dimensional space, the only regular polygons that can create a **tessellation** are equilateral triangles, squares, and hexagons.

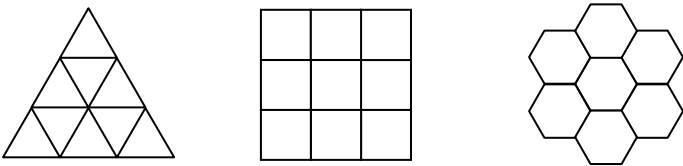

tetrahedron: a polyhedron with four faces.

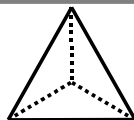

tetrominoes: figures formed using four congruent squares placed so that each square shares a side with at least one other square.

theorem: a proposition to be proven.

translation (or slide): the movement of an object in a given direction along a straight line.

• $\triangle A'B'C'$ is a **translation** of $\triangle ABC$ 6 units to the right, and 1 unit up.

transversal: a straight line that intersects two or more straight lines.

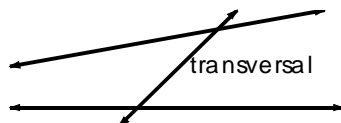

trapezoid: a quadrilateral with exactly one pair of parallel sides.

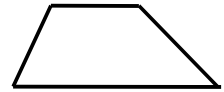

triangle: a polygon with three sides.

Trichotomy Property: for all real numbers, a and b , exactly one of the following is true;
 $a = b$, $a > b$, or $a < b$

trinomial: an algebraic expression consisting of three terms separated by addition or subtraction signs.

triominoes: figures formed using three congruent squares placed so that each square shares a side with at least one other square.

Uniqueness Property: a property that guarantees that when two people work the same problem they should get the same result.

universal quantifier: \forall is the universal quantifier; it is read “for all,” “for every,” or “for each.”

valid argument: an argument in which all the premises are true and the conclusion is true; the conclusion follows logically from the premises; also known as **deduction** or a **proof**.

variable: a letter or symbol used to represent a number or a group of numbers.

vertex: the turning point of a parabola; the common endpoint of the two intersecting rays of an angle.

vertical angles: two non-adjacent angles formed by two, straight, intersecting lines.

- In the diagram given, $\angle 1$ and $\angle 3$ are vertical angles. So are $\angle 2$ and $\angle 4$.

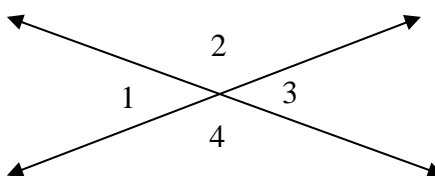

vertex angle of an isosceles triangle: the angle formed by the equal sides of the triangle.

vertex of a polygon: a point where two sides of a polygon meet.

volume: the number of cubic units it takes to completely fill a three-dimensional figure.

• The following are examples of **volume** problems.

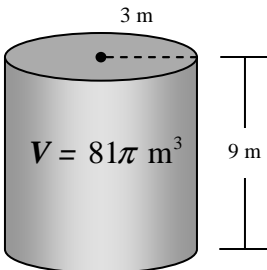
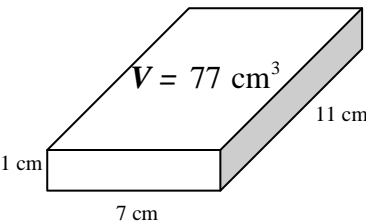

The diagram shows two three-dimensional figures. On the left is a rectangular prism with a length of 7 cm, a width of 11 cm, and a height of 1 cm. The volume is given as $V = 77 \text{ cm}^3$. On the right is a cylinder with a radius of 3 m and a height of 9 m. The volume is given as $V = 81\pi \text{ m}^3$.

whole numbers: the collection of natural numbers including zero; $\{0, 1, 2, 3, \dots\}$

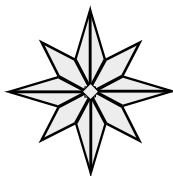

End of Glossary